

REINHOLD ENVIRONMENTAL®



2023 Reinhold/PCUG Round Table Presentation

Cohosted by Duke Energy and Vistra in The Westin Hotel,
Cincinnati, OH on June 26-27, 2023

All presentations posted on this website are copyrighted by **REINHOLD ENVIRONMENTAL®** (RE). Any unauthorized attempts to print, to download, to modify, to incorporate into other presentations, to link to other websites or to obtain copies for any other uses than the training of attendees to RE Conferences is expressly prohibited unless approved in writing by RE or the original presenter. RE does not assume any liability for the accuracy or contents of any materials in this library which were presented and/or created by persons who were not employees or subcontractors of RE.

IGS Environmental Solutions

Meeting New Good Neighbor Plan NOx Limits:

How to Get More Out of Your SCR

Presenter: Andrew Kline



www.integratedglobal.com



EPA

Nat Gas and Oil EGUs: New EPA Limits

- Existing SCRs at oil- and gas-fired steam units and simple cycle units is 0.03 lb/mmBtu
- Combined-cycle units with SCR achieves 0.012 lb/mmBtu
- New SCR performance control limit is 0.05 lb/mmBtu



www.integratedglobal.com

Beginning in the 2026 ozone season, NOX Emissions Standards for Nine Large Industries

- reciprocating internal combustion engines in Pipeline Transportation of Natural
- Gas;
- kilns in Cement and Cement Product Manufacturing;
- reheat furnaces in Iron and Steel Mills and Ferroalloy Manufacturing;
- furnaces in Glass and Glass Product Manufacturing;
- boilers in Iron and Steel Mills and Ferroalloy Manufacturing, Metal Ore Mining,
- Basic Chemical Manufacturing, Petroleum and Coal Products Manufacturing, and
- Pulp, Paper, and Paperboard Mills; and
- combustors and incinerators in Solid Waste Combustors or Incinerators

**GNP NOx
Emissions:
*Not Just
EGU
Utilities!***





New NOx Regulations

New Challenges We Face:

- New SCRs to be Built, and FAST!!!
 - Average SCR is 3 years from start to finish
 - OEMs have limited capacity
- Existing SCRs will be Held to Higher Standard



www.integratedglobal.com

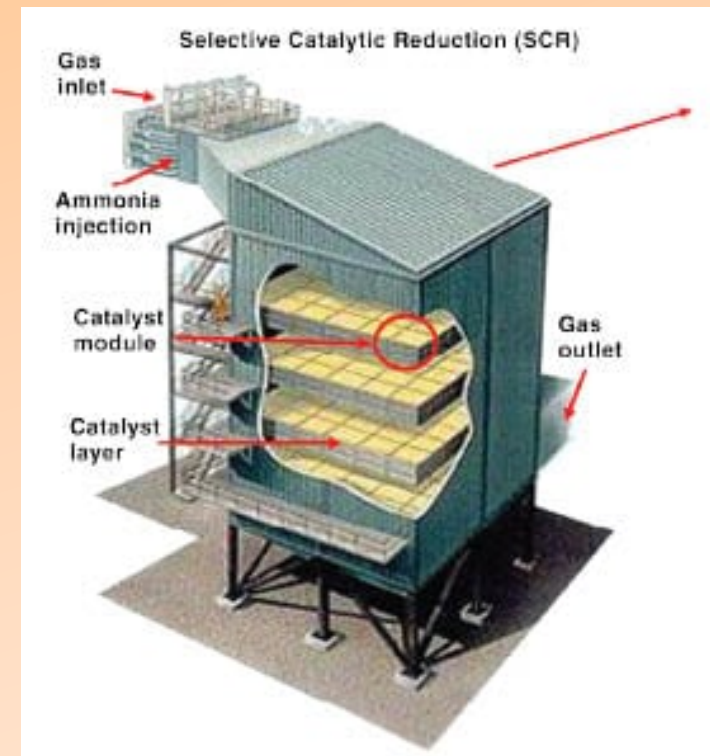
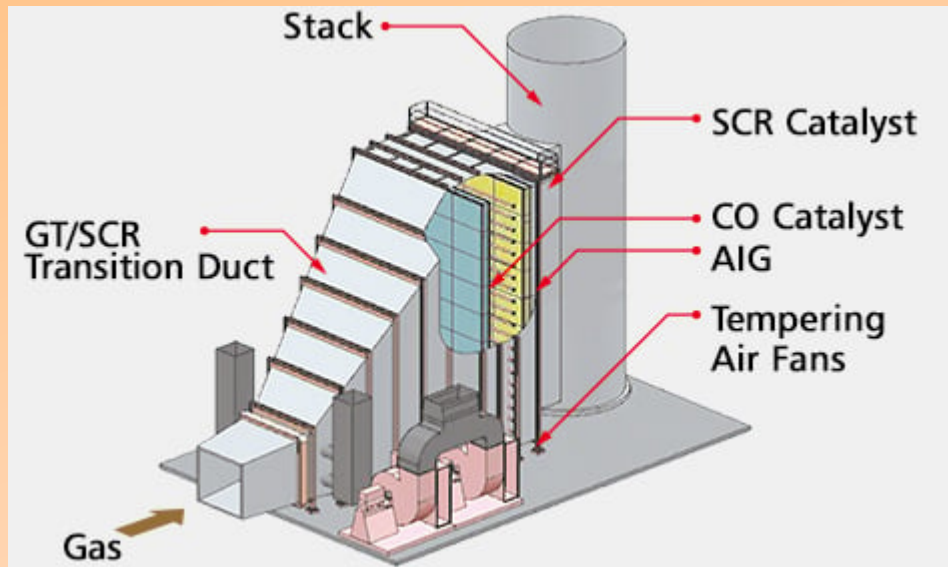

Solid Fuel vs. Gas



Different Root SCR Issues; Same Outcome:

- Solid Fuel – LPA & Fly Ash & Other Particulate
- Natural Gas – Fibrous Material
- Either Way, it Equals Reduction of Catalyst Area and Poor Flow Distribution



www.integratedglobal.com



Nat Gas SCR Fouling



SCR Fouling:

- Primarily Caused by Refractory or Insulation Fibers
- Volume of Material Varies, can be Caused Over Time or by Upset Conditions
- Fibrous Material Blocks the Catalyst Face
- Causes Flow Disruptions and Pressure Drops



www.integratedglobal.com

Preventative Option: Fine Particle Filtration Screen

- Installed Upstream of the SCR Catalyst
- Designed to Capture and Remove Fibrous Material
- Designed to minimize dP
- Air Cannon Cleaning System to Remove Material from Screen and Into Collection Area

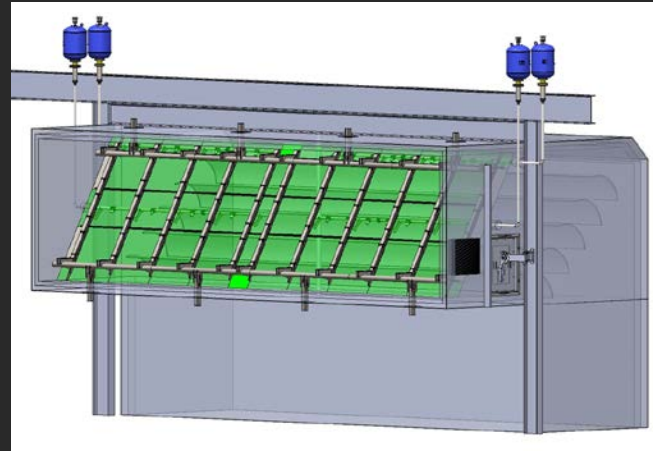

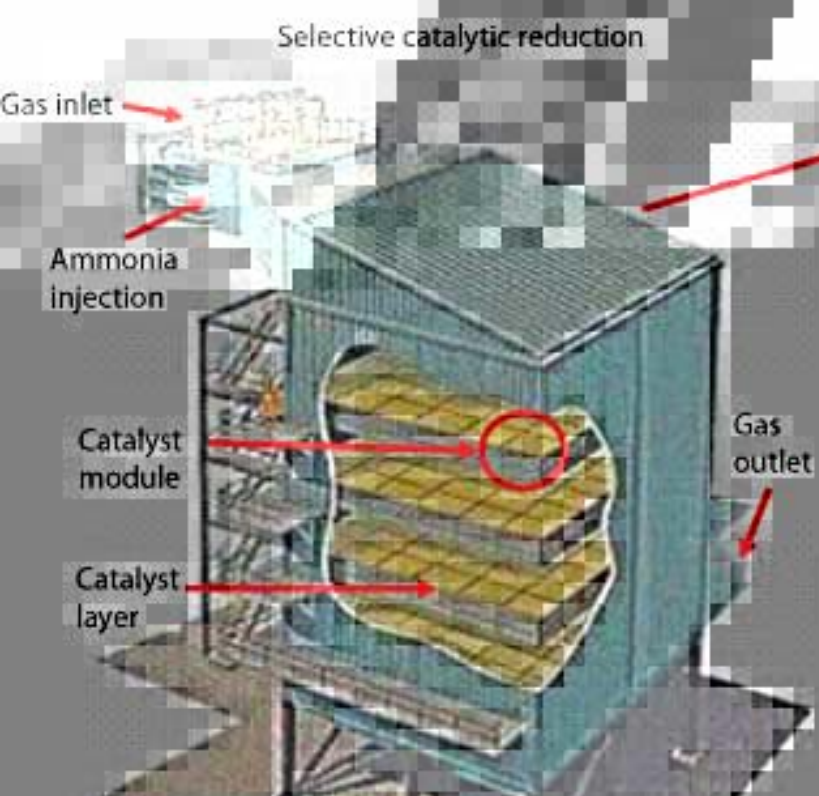

Traditional SCR Challenges

- Poor SCR Design & Inadequate Cleaning System
- Poor Maintenance Practices
- Cycled Loading
- Upset Operating Conditions

In the past, some of us could get away with these practices. That is all changing!



www.integratedglobal.com



Solid Fuel SCR Buildup



Coal Fired SCR Buildup Causes:

- LPA Present in SCR
- Gas Flow Distribution
- Ash Flow Distribution
- Inadequate Outage Maintenance Procedures



www.integratedglobal.com

Costs of SCR Buildup

1. **DeNO_x Reduction**
2. **Excessive Pressure Drop**
3. De-Rating Boiler due to 1 and/or 2
4. Severe Reduction in Catalyst Life
5. Excessive Ammonia Usage
6. Corrosion damage due to Ammonia Slip
7. Forced Outages to Remove Ash
8. Cost of Removing Ash
9. **Non-Compliance Penalties**



Elimination of SCR Buildup:

- **LPA Screens to Prevent LPA from Reaching SCR**
- Air Cannons to Address Ash Flow and Gas Flow Distribution Issues
- Proper Catalyst and Sonic Horns to Improve Overall Ash Capacity
- CatFlow Screens to Protect Catalyst and Enhance Online Cleaning
- Proper Outage Procedures
10% Buildup Is No Longer Acceptable to Effectively Meet Compliance!

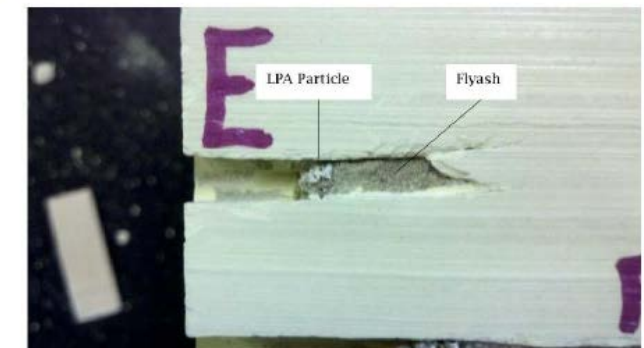
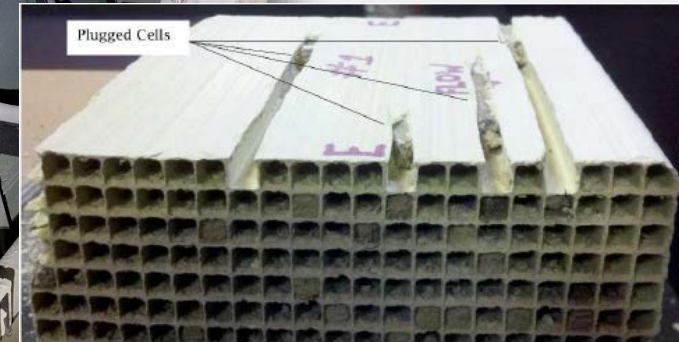
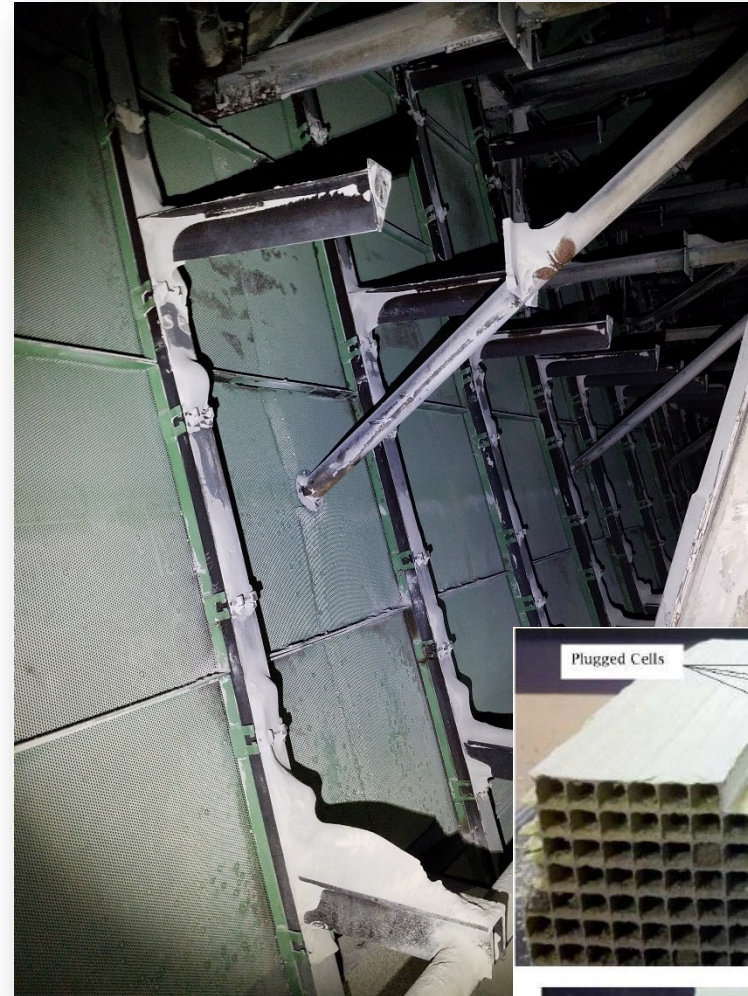

Elimination of SCR Buildup:

- LPA Screens to Prevent LPA from Reaching SCR
- **Air Cannons to Address Ash Flow and Gas Flow Distribution Issues**
- Proper Catalyst and Sonic Horns to Improve Overall Ash Capacity
- CatFlow Screens to Protect Catalyst and Enhance Online Cleaning
- Proper Outage Procedures
10% Buildup Is No Longer Acceptable to Effectively Meet Compliance!

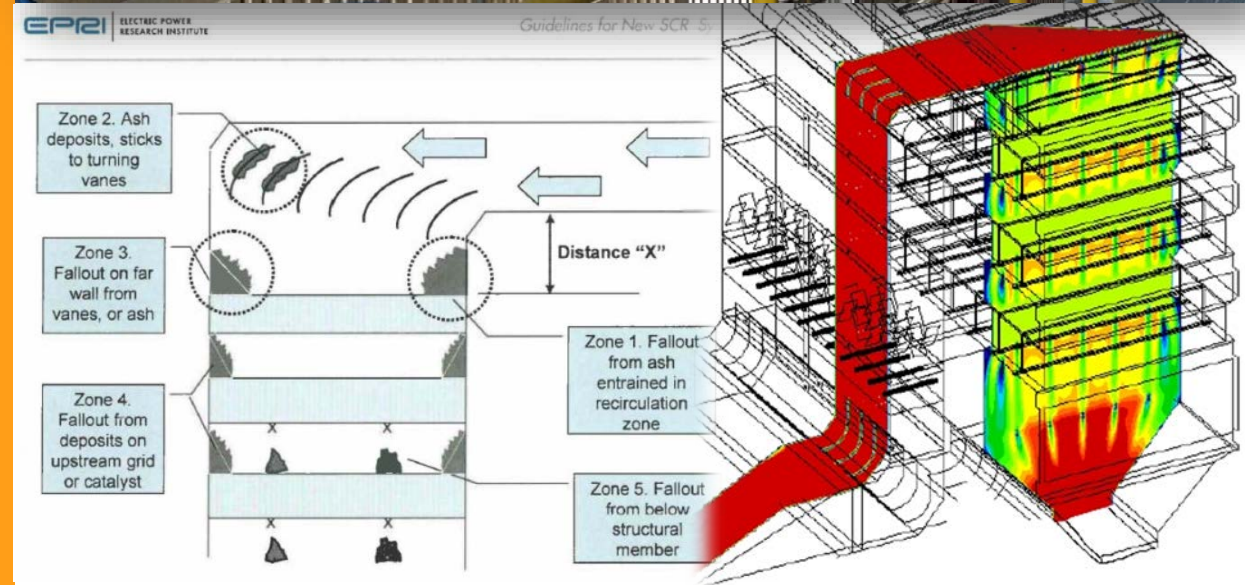

Elimination of SCR Buildup:

- LPA Screens to Prevent LPA from Reaching SCR
- Air Cannons to Address Ash Flow and Gas Flow Distribution Issues
- **Proper Catalyst and Sonic Horns to Improve Overall Ash Capacity**
- CatFlow Screens to Protect Catalyst and Enhance Online Cleaning
- Proper Outage Procedures
10% Buildup Is No Longer Acceptable to Effectively Meet Compliance!

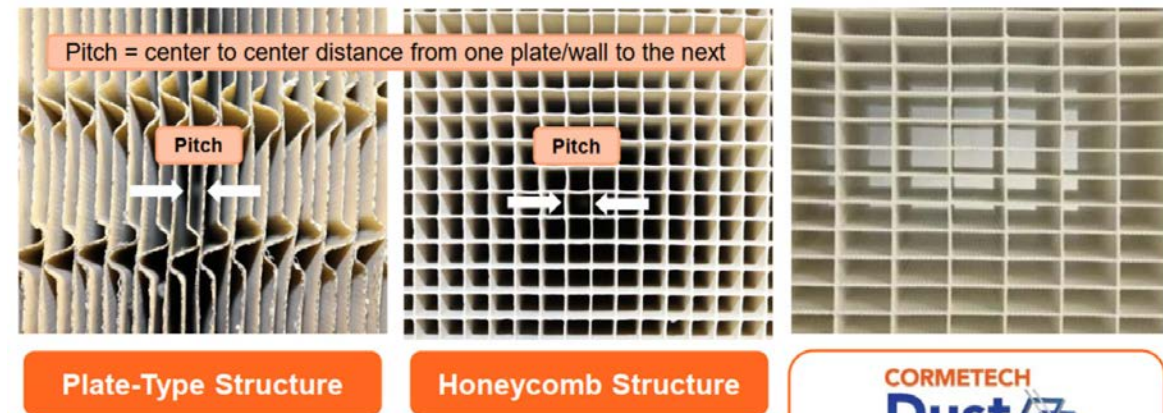

Specifically designed for high dust environments

Elimination of SCR Buildup:

- LPA Screens to Prevent LPA from Reaching SCR
- Air Cannons to Address Ash Flow and Gas Flow Distribution Issues
- Proper Catalyst and Sonic Horns to Improve Overall Ash Capacity
- **CatFlow Screens to Protect Catalyst and Enhance Online Cleaning**
- Proper Outage Procedures

10% Buildup Is No Longer Acceptable to Effectively Meet Compliance!

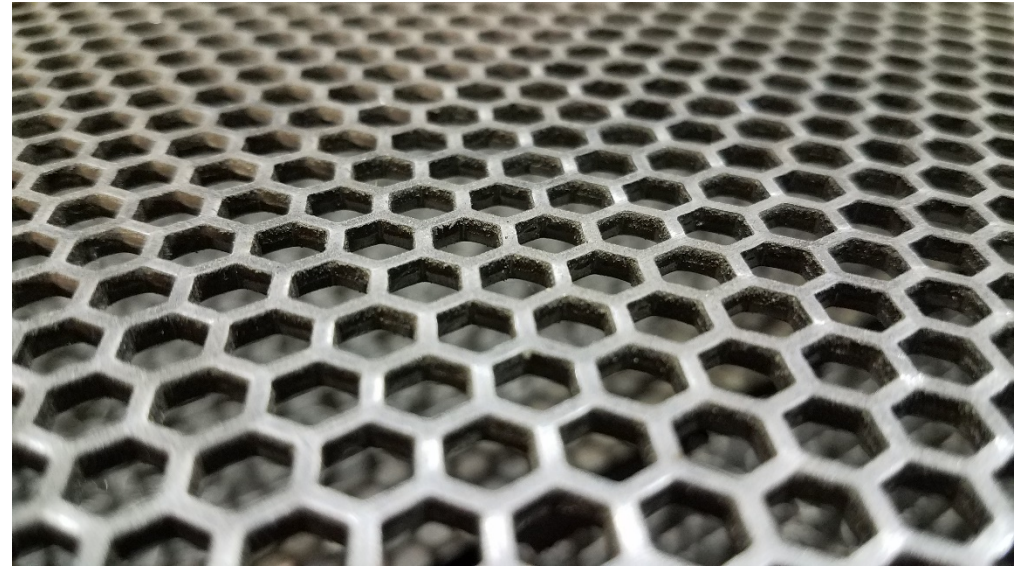

Elimination of SCR Buildup:

- LPA Screens to Prevent LPA from Reaching SCR
- Air Cannons to Address Ash Flow and Gas Flow Distribution Issues
- Proper Catalyst and Sonic Horns to Improve Overall Ash Capacity
- CatFlow Screens to Protect Catalyst and Enhance Online Cleaning
- **Proper Outage Procedures**
10% Buildup Is No Longer Acceptable to Effectively Meet Compliance!



95% Clean SCR Guarantee

*Not Only Possible, It's the New
Standard!*

**Key to Successful SCR
Operation: Experience**

The IGS Global SCR Study is a compilation of white papers and case studies from various sources throughout the industry, compiled in a research paper format.

**If you are interested in receiving a copy of
this book, please send an email request to:**

andrew.kline@integratedglobal.com

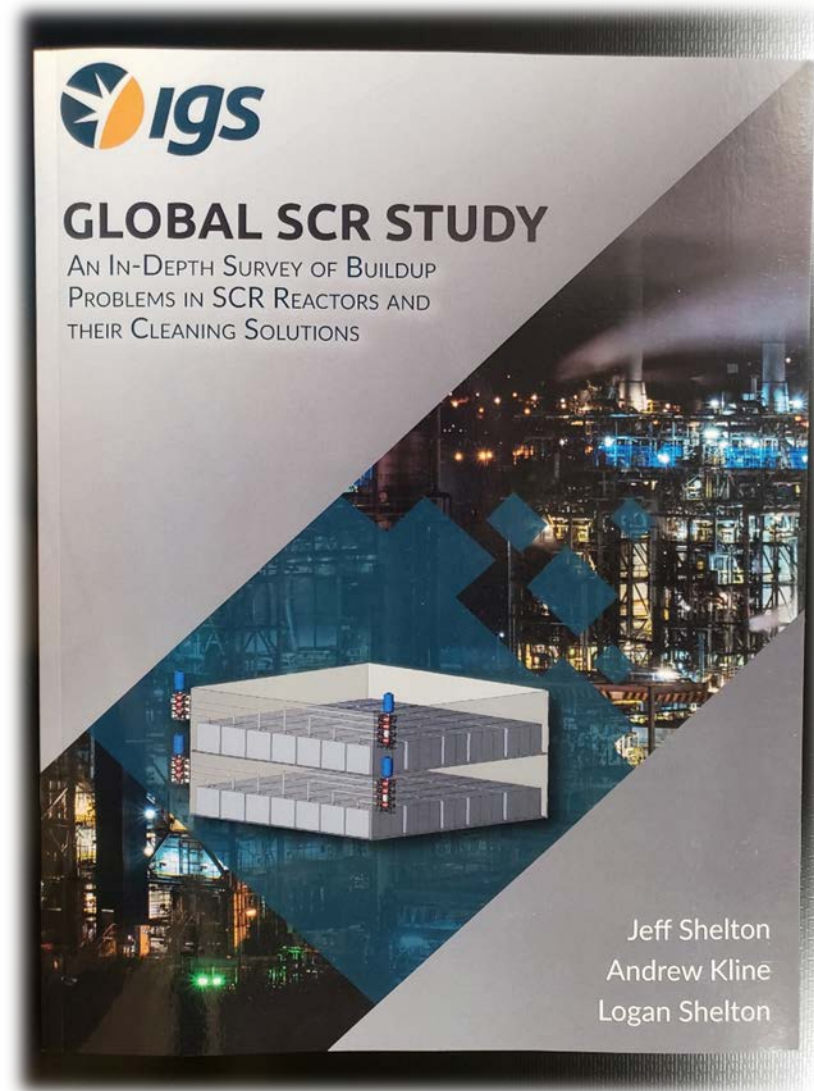

A photograph of an industrial facility, likely a power plant or refinery, showing a long, narrow walkway with a yellow safety railing. The walls are made of corrugated metal. In the foreground, a large blue spherical component is visible, connected to various pipes and cables. The scene is brightly lit, and the perspective leads the eye down the length of the facility.

Updated SCR Technologies

Increasing Effectiveness While Decreasing Cost

IGS ENVIRONMENTAL SOLUTIONS

What Makes a LPA Screen Successful?

LPA SCREEN DESIGN CONSIDERATIONS:

- *Reliable LPA filtration capabilities*
- ***Economically Efficient Design***
 - *Low System Pressure Drop*
 - *Improve Flow Distribution*
 - *Reliable Screen Cleaning*
- *Maximum Screen Life*
- *Ease of Installation and Maintenance*
- *Interchangeable Standard Components*
- *Screen Management Program*

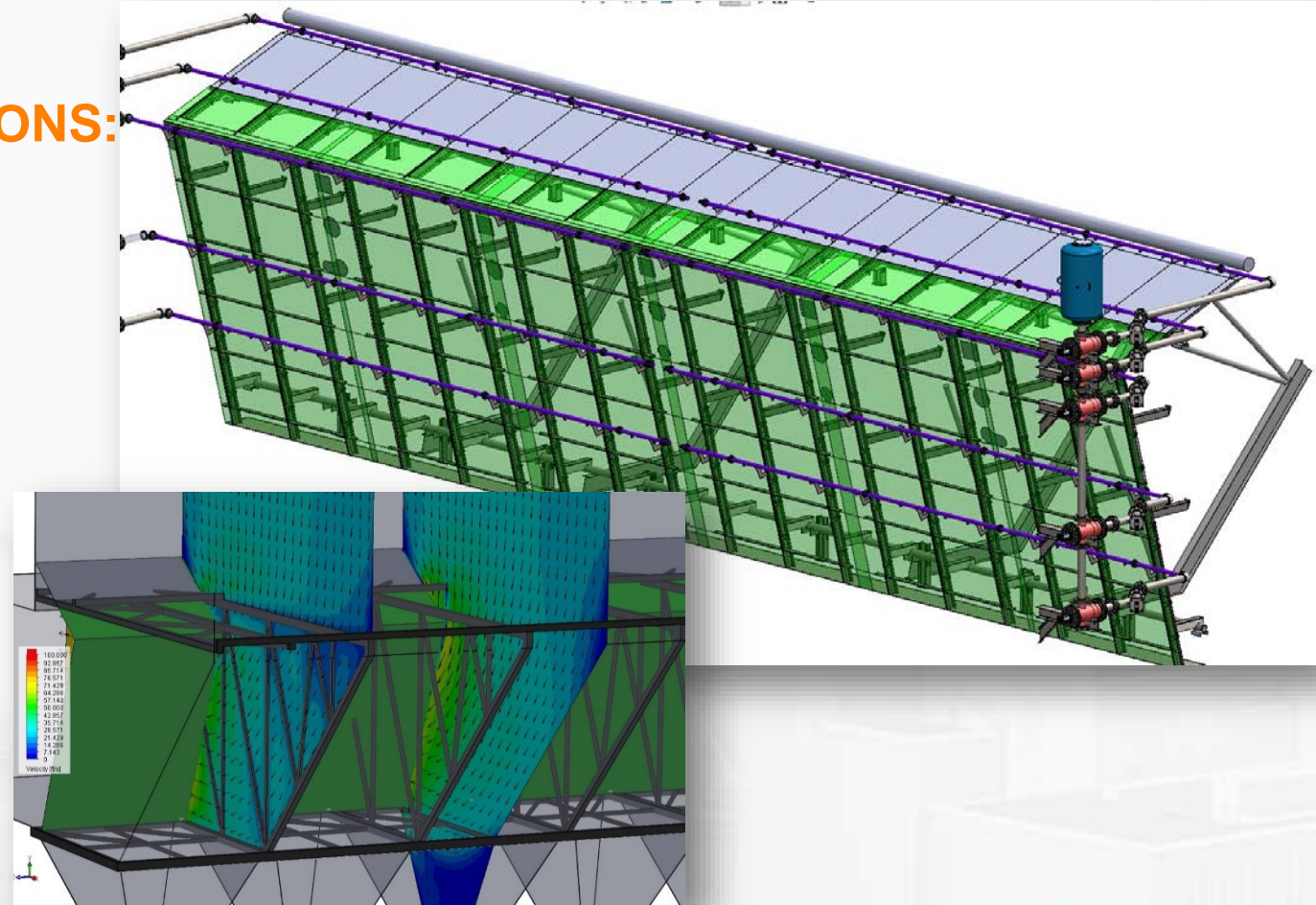

LPA Screen Maintenance is Critical – Yet Often Overlooked!

LPA SCREENS ARE LIKE BRAKE PADS, YOU NEED TO CHANGE THEM BEFORE THEY FAIL!!!

- *Typical Quality LPA Screen Life 4-6 Years*
- *Important to Replace Worn Panels Prior to Failure*
- *When Panels Begin to Fail, they Fail Quickly!*
- *Having 15-20% Spare Panels in Stock Allows for Maintenance during Short Outages*

Ask your supplier to help you develop a maintenance program customized for your LPA screen system to fit your specific needs.



LPA Screen Maintenance is Critical – Yet Often Overlooked!

LPA SCREENS ARE LIKE BRAKE PADS, YOU NEED TO CHANGE THEM BEFORE THEY FAIL!!!

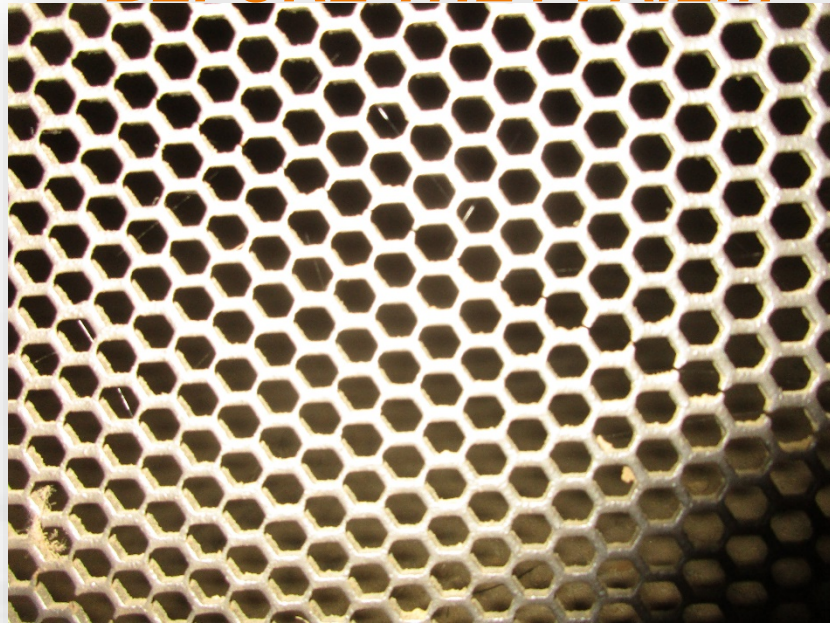

Early Signs of Wear

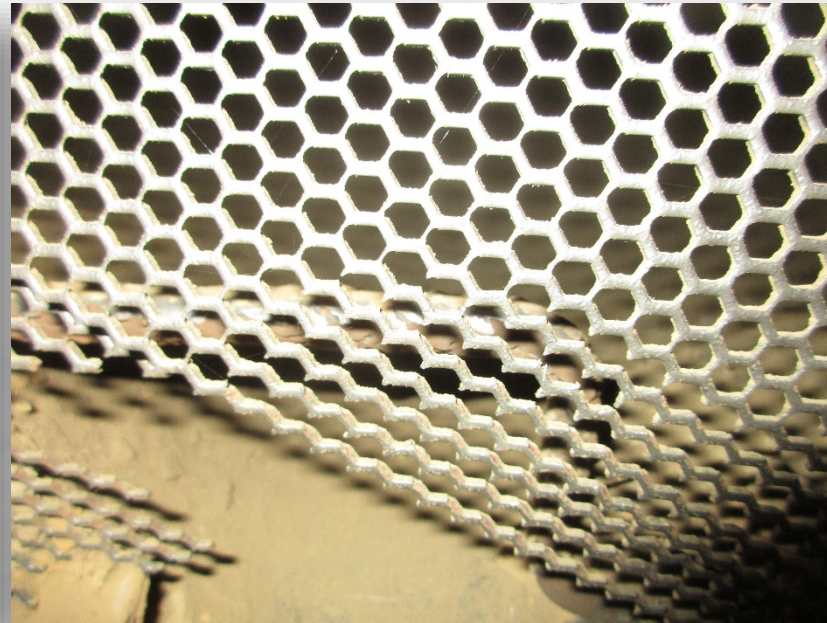

Early Stages of Failure



Severe Failure

Regular Qualified Inspection is Critical to Protect the SCR Between Outages



Advancements in Protection – Two-Stage Cladding

TWO-STAGE CLADDING SYSTEM:

- *Second coating in addition to HVTS Cladding*
- ***Visual Wear Indicator***
- *Top Coat is able to be Refurbished*
- *Additional Wear Protection*
- *Existing Systems can be Upgraded!*

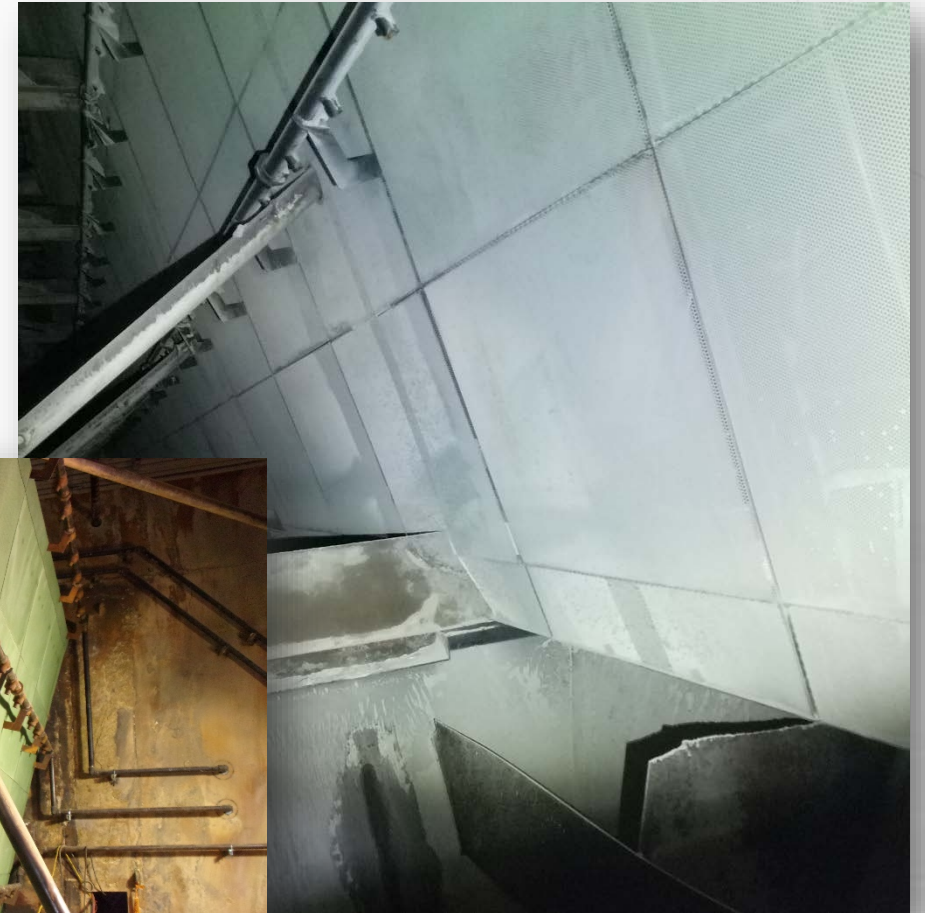
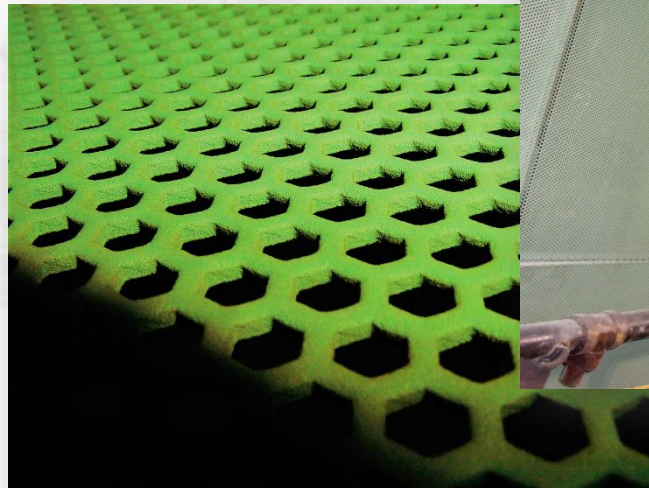

Advancements in LPA Screen Cleaning – Air Cannons

ELIMINATE COSTLY RAPPER SYSTEM:

- **Header Nozzle System**
 - *Turning Vanes*
 - *LPA Screens*
 - *Ductwork*
 - *Custom Applications*
- **LPA Screen Application**
 - *More Effective*
 - *Increased Reliability*
 - *Less Expensive*
 - *No Vibrational Fatigue to Screen*



Advancements in Air Cannon Technology

MULTIPLIER SYSTEM:

- *Lower equipment and installation cost*
- *Less Maintenance*
- *Remote mounting configurations*
- *Can install nozzles in non-traditional locations with limited space*

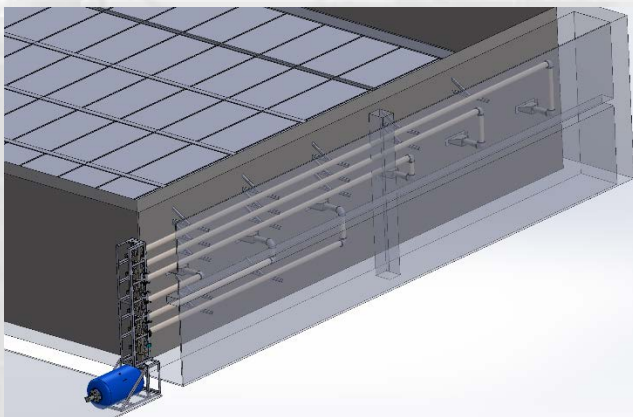

Advancements in Air Cannon Technology

8" BIG BLUE & SCR MONSTER NOZZLE:

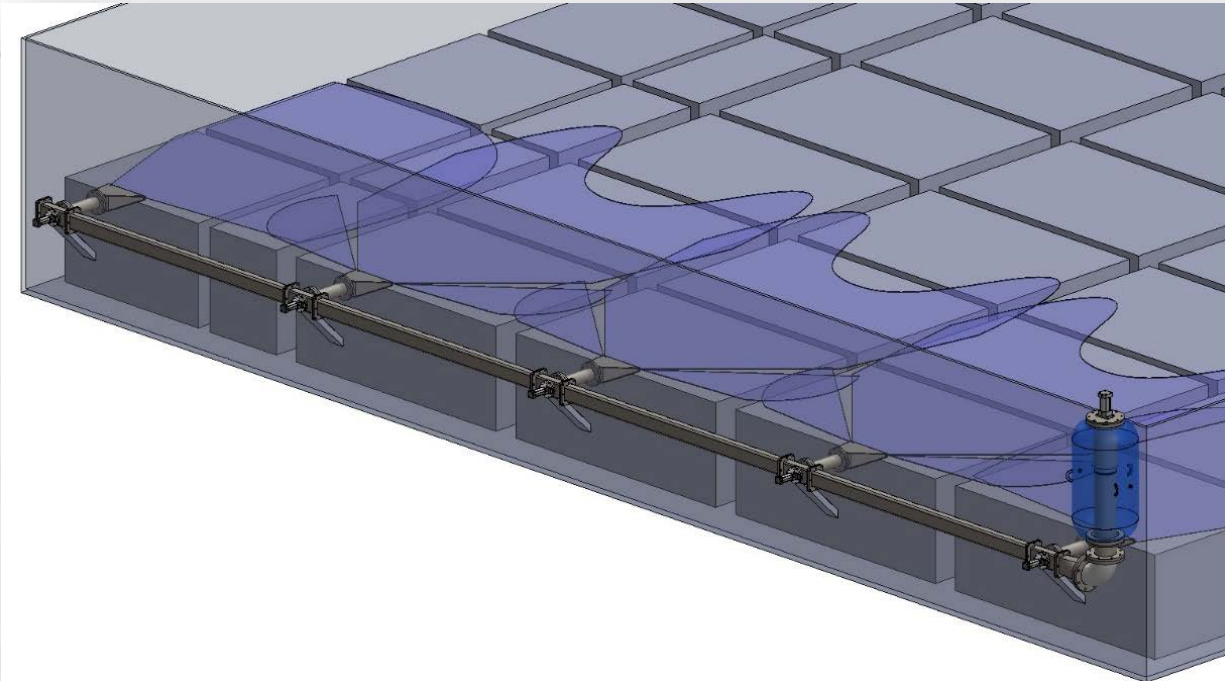

Advancements in Air Cannon Technology

IGS NOZZLE DESIGNS:

- *High Efficiency Fan Jet – Wider Coverage*
- *Monster Nozzle – Deeper Cleaning*



Cleaning Patterns of Various Ash Sweeper Nozzles



IGS High Efficiency Fan Jet Nozzle



Standard Fan Jet Nozzle



High Velocity Fan Jet Nozzle



Catalyst Screens: An Overlooked Technology

ISSUES WITH STANDARD CATALYST SCREENS

- ***They attract buildup—rough surfaces make cleaning more difficult***
- *Hard to remove during an outage to vacuum under*
- *Do not improve airflow*
- *Can Hinder Online Cleaning*
- ***They do not stop Large Particle Ash***



An Engineered Solution

PATENTED CATFLOW SCREENS:

Engineered improvement for

- **SAFETY**
- *Flow Improvement*
- *Reduction of Ash Accumulation*
- *Particle Filtration*
- **Maximum Online Cleaning Efficiency**
- *Protection of Catalyst*



Advancements in Air Cannon Technology

CATFLOW SCREENS EXTENDING PERFORMANCE:

- *Smooth Surface equals more cleaning*
- *Helps extend length of the cleaning blast*
- *Protects catalyst from air cannon blast*
- **SAFER TO WORK ON/AROUND!**



Advancements in Air Cannon Technology



CATFLOW SCREENS EXTENDING PERFORMANCE:

- *Smooth Surface equals more cleaning*
- *Helps extend length of the cleaning blast*
- *Protects catalyst from air cannon blast*
- **SAFER TO WORK ON/AROUND!**



QUESTIONS & DISCUSSION

Andrew Kline

Director – IGS Environmental

+ 1 757-777-2591 – Mobile

andrew.kline@integratedglobal.com

www.integratedglobal.com

